

Over Stroke Marker OSM - guideline for removal



SERVICE TOOLS

Self-centring
chuck or vice

Flathead
screwdriver

Rubber
mallet

Plier

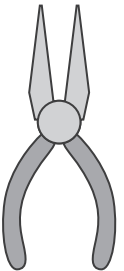
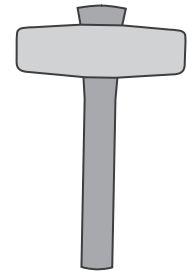
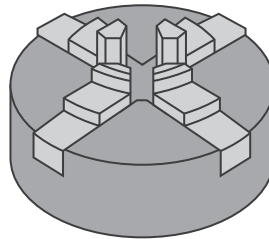

PROCEDURE



1- Secure the cylinder onto a self-centring chuck or a vice.

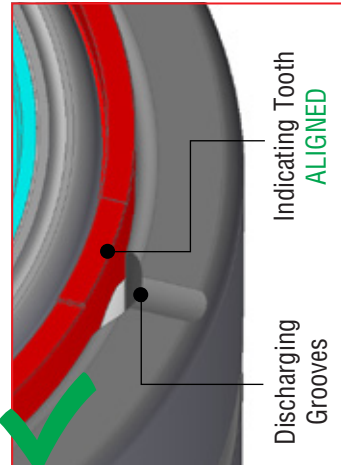

2- On the upper side of the cylinder's body, find the indicating tooth on the OSM ring and the discharging grooves.

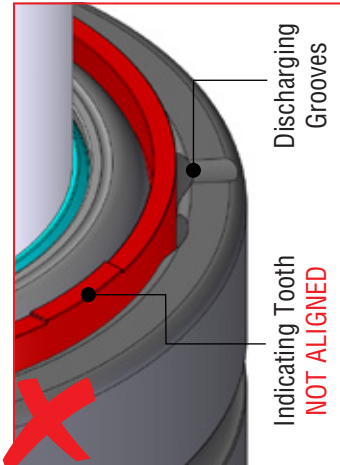

3- If the Indicating Tooth is not aligned with the discharging grooves, reposition it manually.

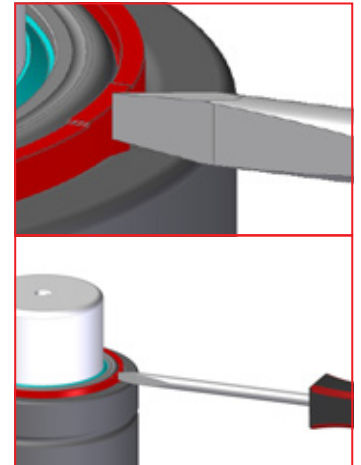

4- Position the flathead screwdriver at the center of the discharging grooves and keep it in contact with the Over Stroke Marker ring.

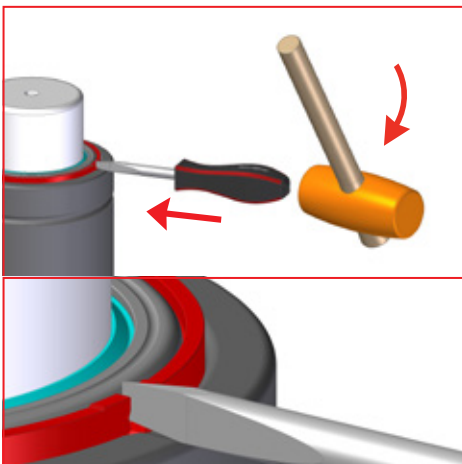

5- By using a rubber mallet, hit the flathead screwdriver to break the OSM ring halfway.

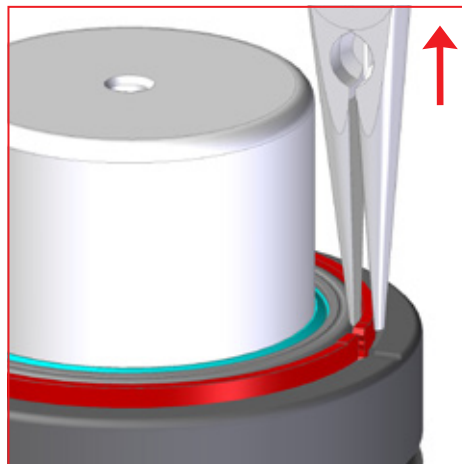

6- Remove the broken Over Stroke Marker ring from its with a pliers.



7- Remove any residual material and clean around the bushing.